

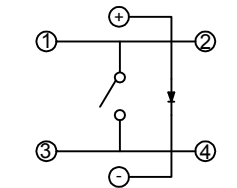

Switch drawings

Dimensional tolerance is ± 0.2mm

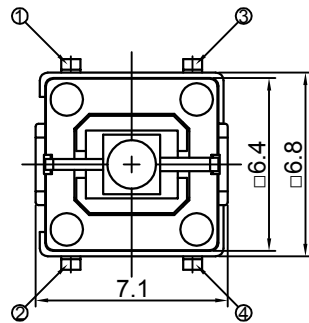
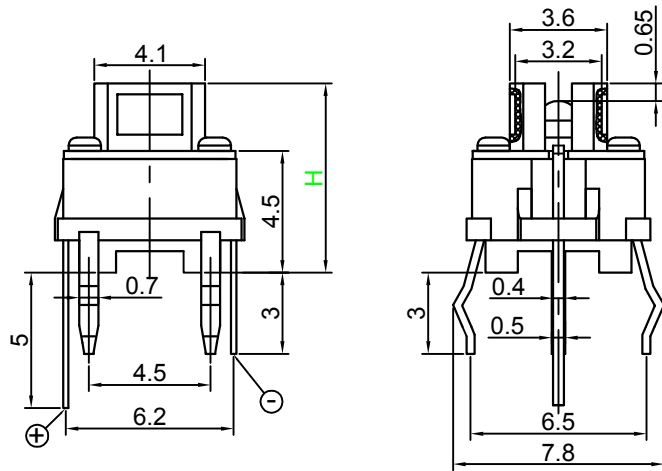

CIRCUIT DIAGRAM

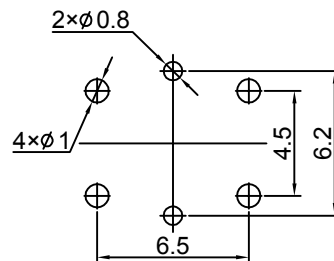

P.C.B. LAYOUT

H	7	13.5
---	---	------

Number Description

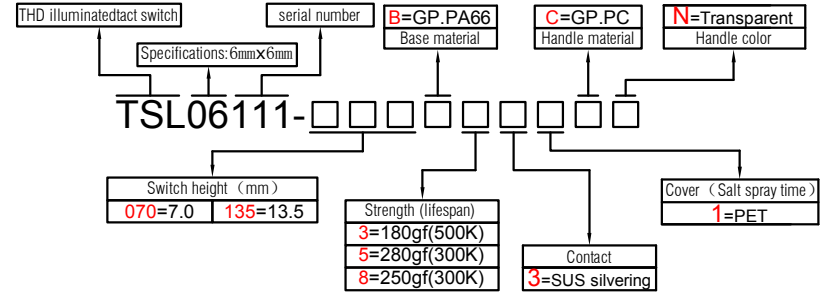

SPECIFICATIONS

Funtion:	Momentary action
Contact Arrangement:	SPST, Normally Open
Termination:	THD illuminated

Environmental

Operating Temperature:	-25 ~ +70 °C
Relative Humidity:	(40 °C) ≤70%

Electrical

Contact Rating:	50mA 12V DC
Dielectric Strength:	250VAC /1min
Contact Resistance:	100mΩMax.
Insulation Resistance:	100MΩMin.
Travel:	0.25±0.1mm

Mechanical

Actuation Force:	Optional
Life Expectancy:	Optional

Materials

1.LED:	Optional
2.Cover:	Optional
3.Stem:	Optional
4.Contact:	Optional
5.Holder:	Optional
6.Terminal:	Ag plating Au plating

