

Switch drawings

Dimensional tolerance is $\pm 0.2\text{mm}$

Number Description

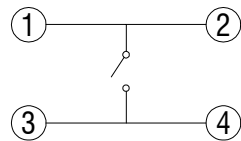
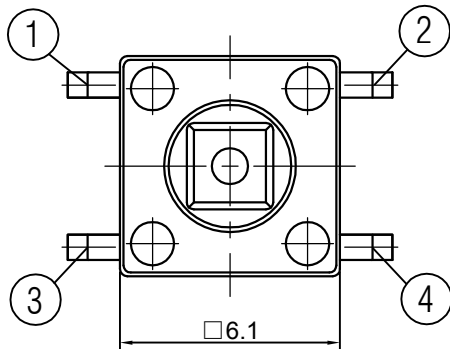
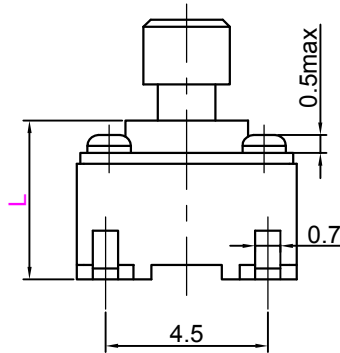
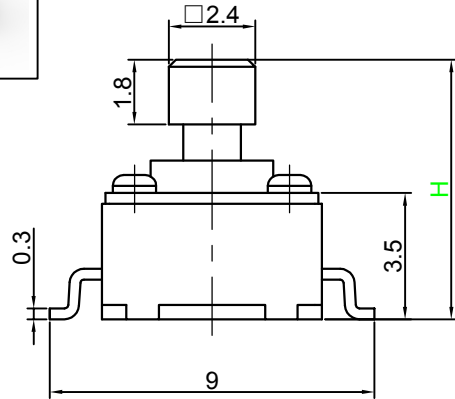

CIRCUIT DIAGRAM

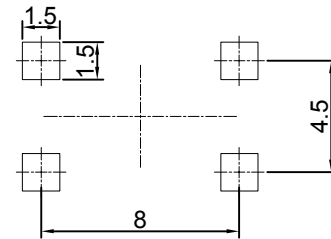

P.C.B. LAYOUT

H	7	7.3	7.5
L	4.2	4.5	4.7

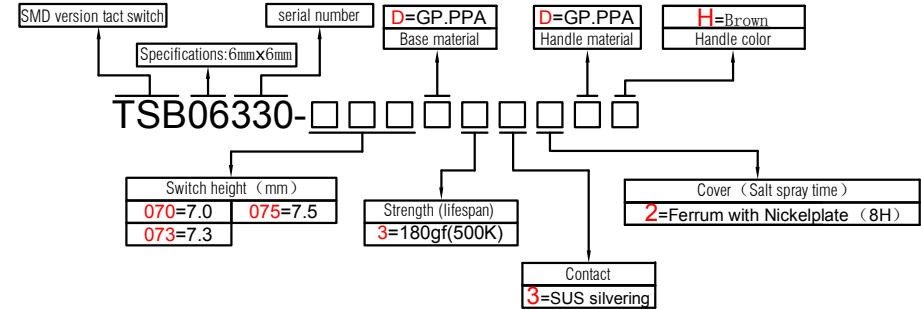

SPECIFICATIONS

Function:	Momentary action
Contact Arrangement:	SPST, Normally Open
Termination:	SMD version

Environmental

Operating Temperature:	-25 ~ +70°C
Relative Humidity:	(40°C) ≤70%

Electrical

Contact Rating:	50mA 12V DC
Dielectric Strength:	250VAC /1min
Contact Resistance:	100mΩMax.
Insulation Resistance:	100MΩMin.
Travel:	0.25±0.1mm

Mechanical

Actuation Force:	Optional
Life Expectancy:	Optional

Materials

1.Cover:	Optional
2.Stem:	Optional
3.Contact:	Optional
4.Holder:	Optional
5.Terminal:	Ag plating Au plating

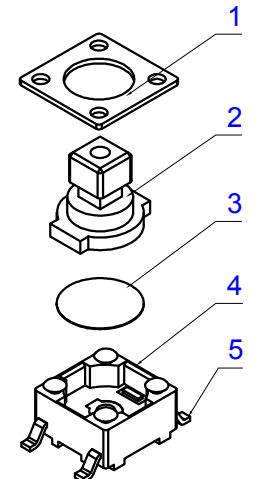

Packaging Specification

standard reel dimensions in mm (not to scale)

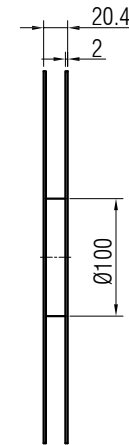
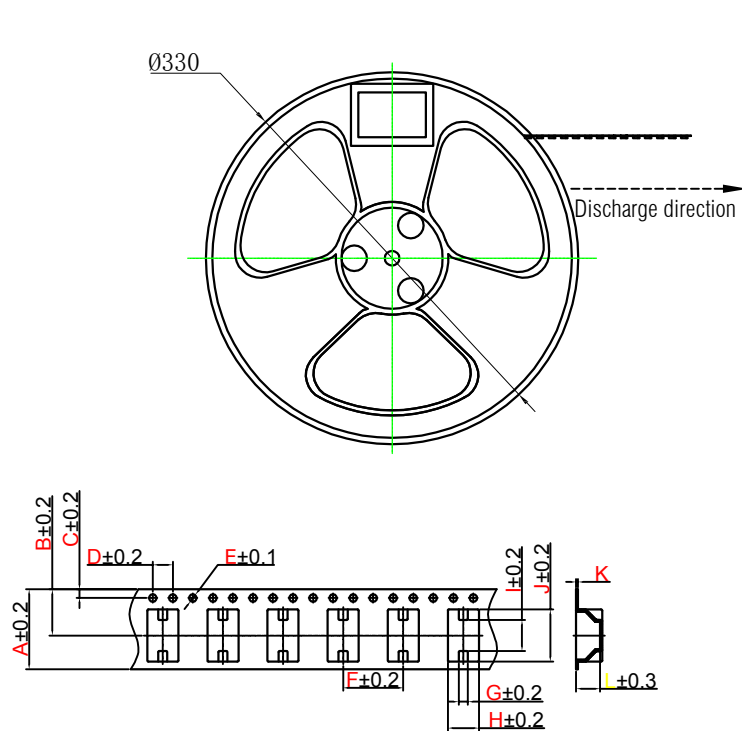

A	B	C	D	E	F	G	H	I	J	K
16	9.25	1.75	4	$\varnothing 1.5$	12	1.8	6.2	6.2	10.4	0.5

L	7.0	8.0	
H	7.0	7.3	7.5
package quantity	700	700	700

1. Clean surface, no damage, no foreign matter, missing material, no flash and other defects affecting the use.
2. The material has good toughness and is not easy to break.
3. Cumulative tolerances of 10 sprockets can not exceed $\pm 0.2\text{mm}$
4. Material Specification: PS Anti-Static Transparent, Thickness 0.5mm
5. In less than 250mm length of T/R does not exceed the maximum bending 1mm, as see below:

